

GPD

GAV30
GAV40 GAV100

OPTOELECTRONICS CORP.

Ge Avalanche Photodiodes

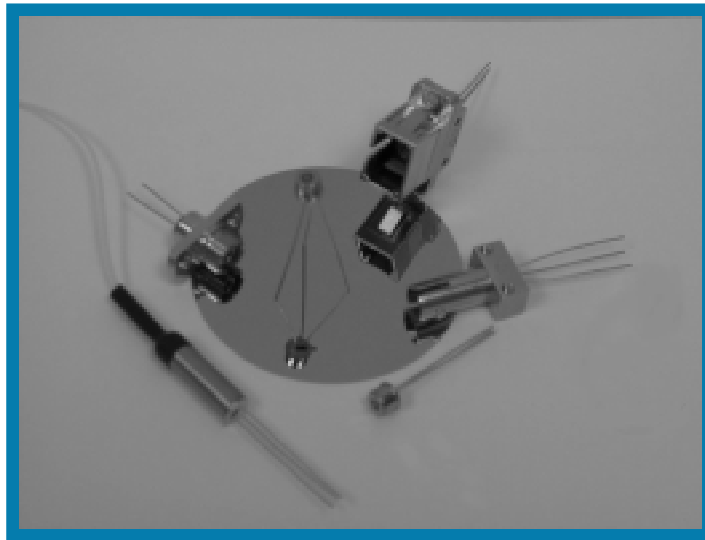

- **OTDR**
- **Infrared Sensing**
- **Telecommunications**
- **Optical Communications**
- **Short Haul Telecom/Datacom Receivers**

GPD Optoelectronics Corp.



Electrical Characteristics @ 25 °C

	GAV30	GAV40	GAV100	Units
Quantum Efficiency (peak)	72 (80)	72 (80)	72 (80)	% min. (typ.)
Responsivity @1300 nm	.76 (.84)	.76 (.84)	.76 (.84)	A/W min. (typ.) M=1
Breakdown Voltage *	20/30/40	20/30/40	20/30/40	V min./typ./max.
Dark Current @0.9V _b	0.2 (0.08)	0.2 (0.10)	1.0(0.3)	μA max. (typ.)
Capacitance @ 20V **	0.9 (0.7)	1.0 (0.8)	1.8 (1.6)	pF max. (typ.)
Multiplied Dark Current	8	12	100	typ. M=1
Cutoff Frequency (-3dB)	2.0(2.5)	1.5 (2.0)	0.6(0.9)	GHz min. (typ.)
Excess Noise Figure	0.95 (all sizes) BW=1MHz M=10 I _{ph} =2μA typ.			
Excess Noise Factor	9 (all sizes) @1300 nm, f=300MHz typ.			
Temperature Coefficient of V _b	0.1 (all sizes)		%/°C	

* I_R=100μA ** f=1MHz

Physical Specifications

	GAV30	GAV40	GAV100
Active Diameter (μm)	30	40	100
Case Styles	TO-46 (modified)/TO-46 SM and MM pigtail, active mounts and ceramic substrates		

Maximum Ratings

	GAV30	GAV40	GAV100	Units
Storage Temperature	-40 to 85	-40 to 85	-40 to 85	°C
Operating Temperature	-10 to 60	-10 to 60	-10 to 60	°C
Reverse Current	0.2	0.4	1.0	mA
Forward Current	20	80	100	mA

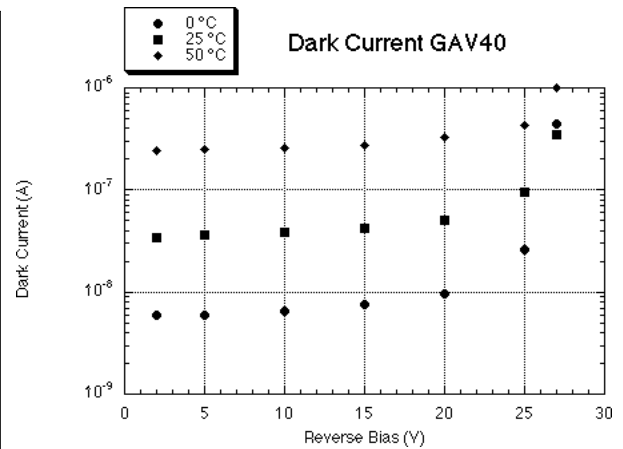
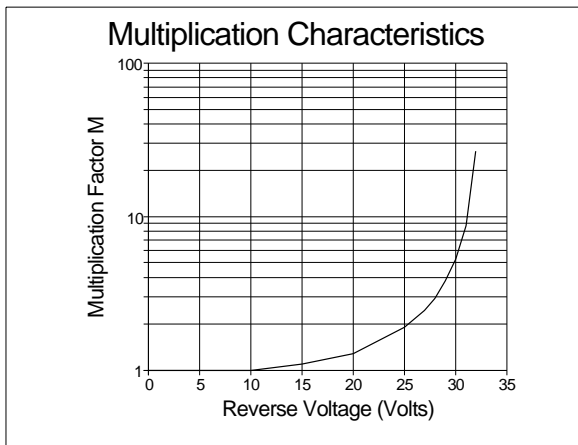

Package Outlines

Dimensions in mm. (in.). Many other packages are available.

TO-46 SM Pigtail

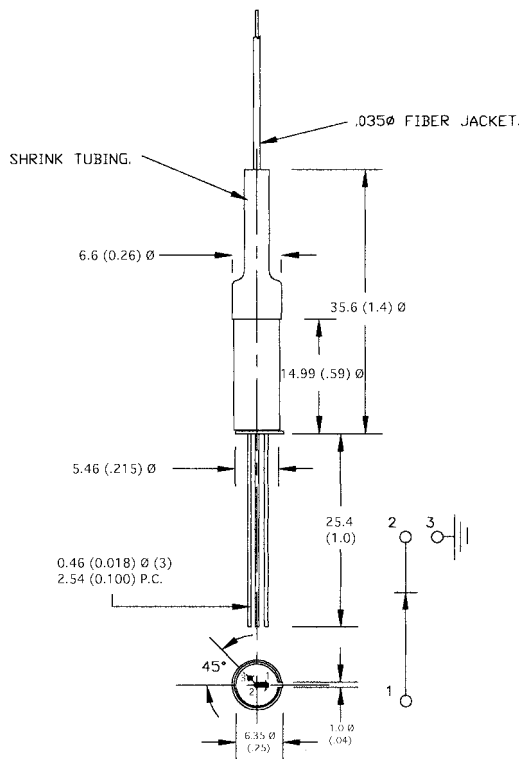

TO-46 (modified)

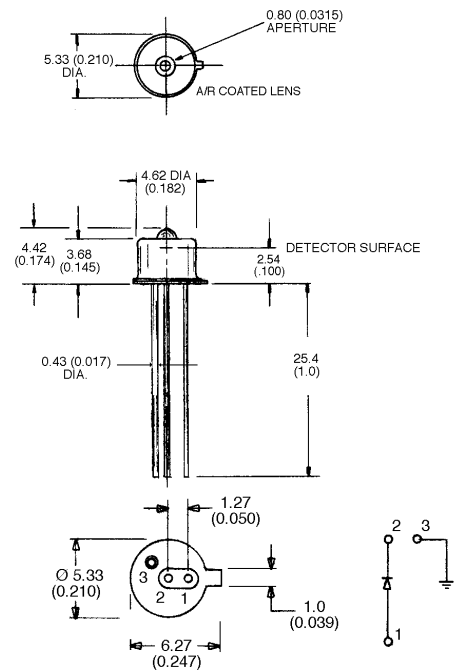



Ceramic Submount Outlines

Dimensions in mm (in.)

CS-1

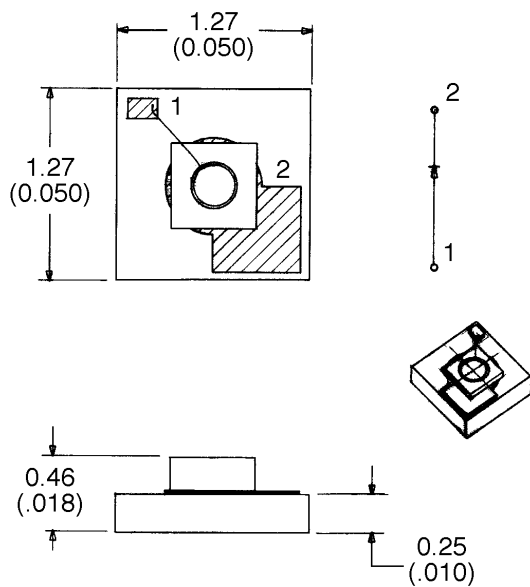

CS-2

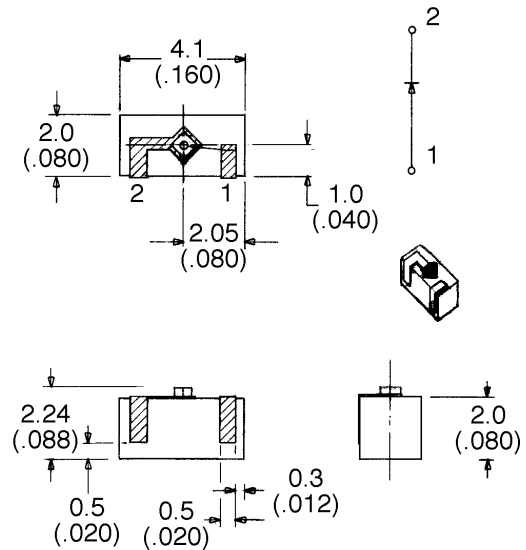

GPD Optoelectronics Corp. (Formerly Germanium Power Devices Corp.) has been a manufacturer of power transistors and diodes since 1973 and a manufacturer of infrared photodetectors for more than ten years. GPD offers Germanium p-n, p-i-n, APD and InGaAs p-i-n high-speed and large area photodetectors for infrared radiation detection and telecommunications applications. GPD can offer you a photodetector that meets your technical and cost requirements.

GPD maintains an inspection system in accordance with MIL-I-45208. Photodiodes are subjected to Bellcore testing requirements(TA-NWT-00093), MIL-STD-883 test methods and/or customer specifications.

GPD Optoelectronics Corp.
7 Manor Parkway
Salem, NH 03079-2842
Tel: (603) 894-6865 Fax: (603) 894-6866
E-mail address: sales@gpd-ir.com
Web Site: <http://www.gpd-ir.com>