

APPLICATIONS

- Pyrometry
- Spectroscopy
- Optical Testing
- Medical Diagnostics

AVAILABLE OPTIONS

- Custom Lenses, Filters, and Anti-Reflective Coatings
- Fiber-Optic Packaging
- Extended InGaAs to 2.6 μ m
- Integrated Electronics:
 - Thermo-Electric Cooler
 - Transimpedance Amplifier

Packaging Configurations

Type	Package	Top Chip	Bottom Chip	Window
InGaAs over InGaAs	TO-39	2mm dia.	2mm dia.	Molded Glass ¹
InGaAs over InGaAs ²	TO-39	1mm dia.	1mm dia.	Molded Glass
Si ³ over InGaAs	TO-39	2.6mm sq.	2mm dia.	Molded Glass
Si ³ over InGaAs	TO-39	2.6mm sq.	1mm dia.	Molded Glass
Si over Ge	TO-8	5.7mm sq.	5mm dia.	AR Coated Sapphire

¹Molded glass windows are uncoated

²1mm over 1mm available Q3 of 2026

³High- and low-resistance Si available

Figure 1. InGaAs/InGaAs 1.7 μ m Cutoff Responsivity vs. Wavelength (Pyrometer Applications)

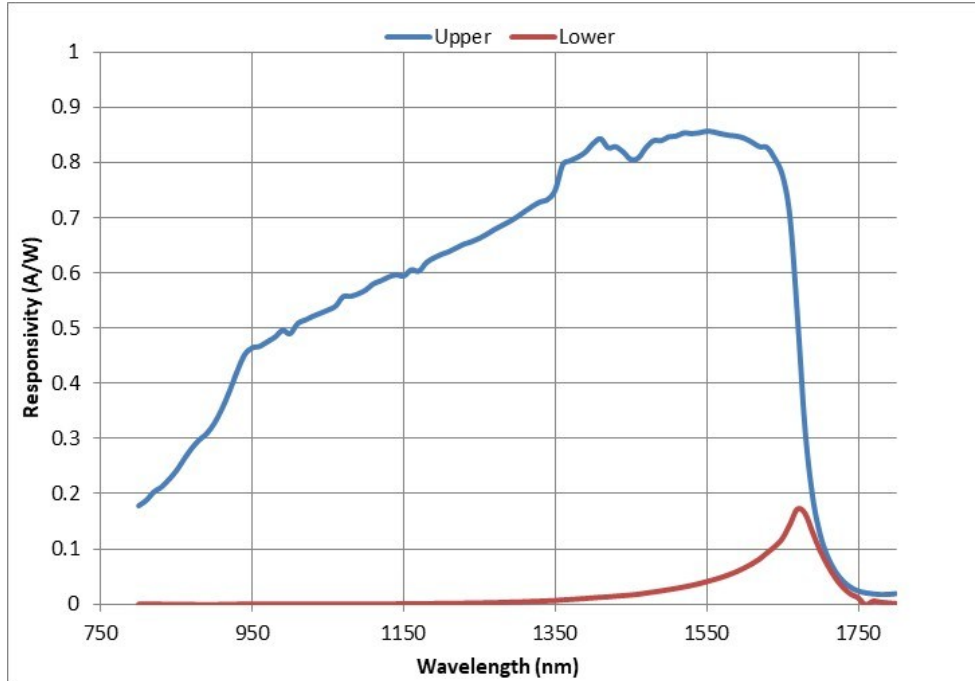

Figure 2. Si/InGaAs Responsivity vs. Wavelength

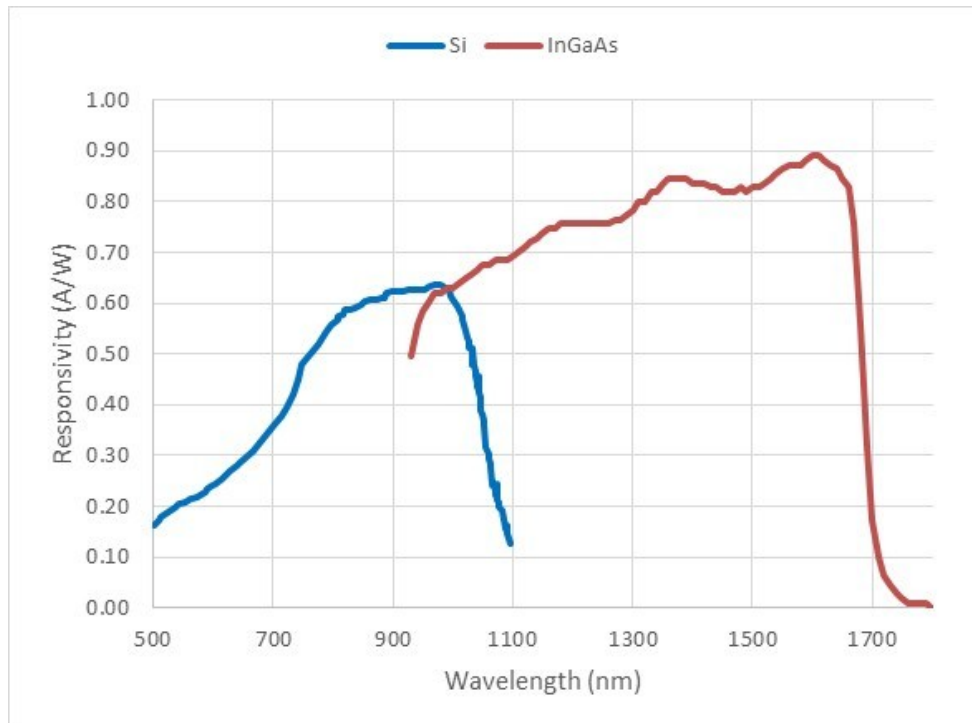
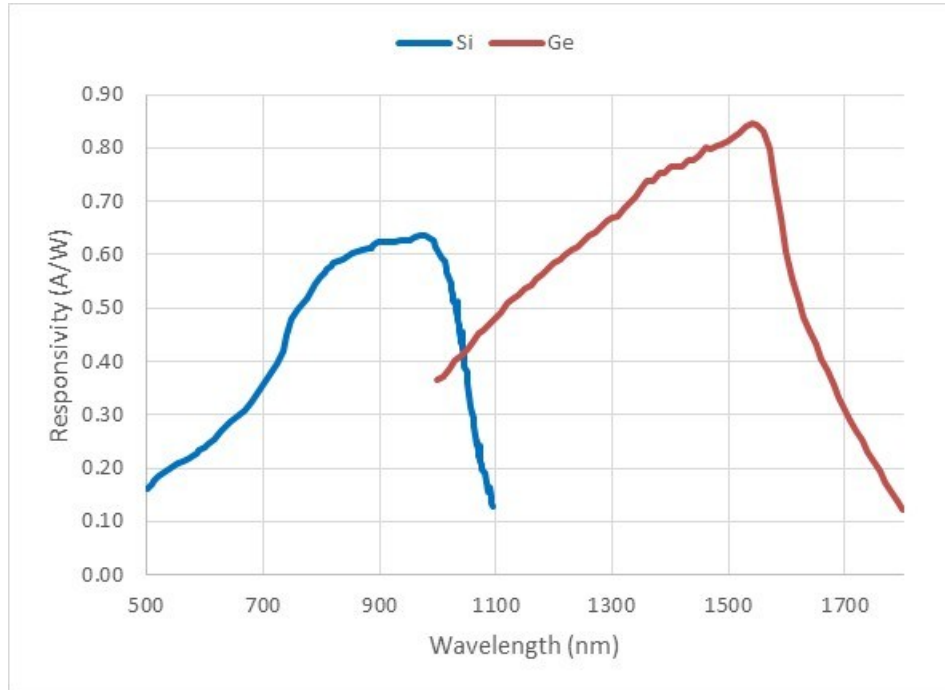

Figure 3. Si/Ge Responsivity vs. Wavelength



GPD QUALIFICATIONS

Our compliance, certificates, and capabilities

- ✓ **ISO 9001:2015**
- ✓ **Quality Assurance Provisions**
- ✓ **DDTC/ITAR registered**
- ✓ **MIL-STD-883**
- ✓ **MIL-STD-750**
- ✓ **Space-qualified designs**
- ✓ **High-reliability assembly and environmental/radiation test**
- ✓ **Manufactured in Salem, NH**



Specifications

2mm dia. InGaAs Photodiodes		
Optoelectronic Characteristics @ 23 °C ± 2 °C		
Spectral Response Range ⁴	800-1700	nm
Responsivity @ 850 nm (min/typ)	0.2/0.35	A/W
Responsivity @ 1300 nm (min/typ)	0.85/1.0	A/W
Responsivity @ 1550 nm (min/typ)	0.93/1.1	A/W
R _{shunt} @ 10mV (min/typ)	5/30	MΩ
I _{dark} @ 2V (typ/max)	3/10	nA
Capacitance @ 0V (max)	800	pF
Capacitance @ 3V (max)	300	pF
Linearity (min/typ)	6/8	dBm
Storage Temperature	-40 to 125	°C
Operating Temperature	-40 to 85	°C
Maximum Ratings @ 23 °C ± 2 °C		
Reverse Current	10	mA
Forward Current	10	mA

1mm dia. InGaAs Photodiodes		
Optoelectronic Characteristics @ 23 °C ± 2 °C		
Spectral Response Range ⁴	800-1700	nm
Responsivity @ 850 nm (min/typ)	0.2/0.35	A/W
Responsivity @ 1300 nm (min/typ)	0.85/1.0	A/W
Responsivity @ 1550 nm (min/typ)	0.93/1.1	A/W
R _{shunt} @ 10mV (min/typ)	5/30	MΩ
I _{dark} @ 2V (typ/max)	3/10	nA
Capacitance @ 0V (max)	250	pF
Capacitance @ 5V (max)	110	pF
Linearity (min/typ)	6/8	dBm
Storage Temperature	-40 to 125	°C
Operating Temperature	-40 to 85	°C
Maximum Ratings @ 23 °C ± 2 °C		
Reverse Current	10	mA
Forward Current	10	mA

⁴Available 1.9, 2.1, 2.2, and 2.6μm cutoff wavelengths

Specifications

2.6mm sq. Silicon Photodiodes⁵		
Optoelectronic Characteristics @ 23 °C ± 2 °C		
Spectral Response Range	500-1050	nm
Responsivity @ 500 nm (typ)	0.16	A/W
Responsivity @ 750 nm (typ)	0.49	A/W
Responsivity @ 1000 nm (typ)	0.61	A/W
R _{shunt} 10mV (min) high-resistance	40	MΩ
R _{shunt} 10mV (min) low-resistance	330	kΩ
I _{dark} 0V (max)	0.2	nA
Capacitance @ 0V (max)	5	pF
Linearity (min/typ)	6/8	dBm
Storage Temperature	-40 to 125	°C
Operating Temperature	-40 to 85	°C
Maximum Ratings @ 23 °C ± 2 °C		
Reverse Current	N/A	mA
Forward Current	10	mA

5.7mm sq. Silicon Photodiodes		
Optoelectronic Characteristics @ 23 °C ± 2 °C		
Spectral Response Range	500-1050	nm
Responsivity @ 500 nm (typ)	0.16	A/W
Responsivity @ 750 nm (typ)	0.49	A/W
Responsivity @ 1000 nm (typ)	0.61	A/W
R _{shunt} 10mV (min)	5	kΩ
I _{dark} 0V (max)	15	nA
Capacitance @ 0V (max)	70	nF
Linearity (min/typ)	6/8	dBm
Storage Temperature	-40 to 125	°C
Operating Temperature	-40 to 85	°C
Maximum Ratings @ 23 °C ± 2 °C		
Reverse Current	N/A	mA
Forward Current	10	mA

⁵High-resistance Si

Specifications

5mm dia. Germanium GB Series Photodiodes

Optoelectronic Characteristics @ 23 °C ± 2 °C

Spectral Response Range	800-1700	nm
Responsivity @ 850 nm (typ)	0.30	A/W
Responsivity @ 1300 nm (typ)	0.75	A/W
Responsivity @ 1550 nm (typ)	0.85	A/W
R _{shunt} @ 10mV (min/typ)	2/4	kΩ
I _{dark} (max)	40	μA
Capacitance (max)	3000	pF
Linearity	8	dBm
Storage Temperature	-40 to 125	°C
Operating Temperature	-40 to 85	°C

Maximum Ratings @ 23 °C ± 2 °C

Reverse Current	10	mA
Forward Current	10	mA

5mm dia. Germanium GH Series Photodiodes

Optoelectronic Characteristics @ 23 °C ± 2 °C

Spectral Response Range	800-1700	nm
Responsivity @ 850 nm (typ)	0.30	A/W
Responsivity @ 1300 nm (typ)	0.75	A/W
Responsivity @ 1550 nm (typ)	0.85	A/W
R _{shunt} @ 10mV (min/typ)	10/15	kΩ
I _{dark} (max)	15	μA
Capacitance (max)	6000	pF
Linearity	8	dBm
Storage Temperature	-40 to 125	°C
Operating Temperature	-40 to 85	°C

Maximum Ratings @ 23 °C ± 2 °C

Reverse Current	10	mA
Forward Current	10	mA

GB Series: Designed for high-speed applications with reverse bias >5V
GH Series: Designed for applications with reverse bias <5 V
GV Series: Designed for zero bias applications

Specifications

5mm dia. Germanium GV Series Photodiodes		
Optoelectronic Characteristics @ 23 °C ± 2 °C		
Spectral Response Range	800-1700	nm
Responsivity @ 850 nm (typ)	0.30	A/W
Responsivity @ 1300 nm (typ)	0.75	A/W
Responsivity @ 1550 nm (typ)	0.85	A/W
R _{shunt} @ 10mV (min/typ)	15/20	kΩ
I _{dark} (max)	5	μA
Capacitance (max)	35000	pF
Linearity	8	dBm
Storage Temperature	-40 to 125	°C
Operating Temperature	-40 to 85	°C
Maximum Ratings @ 23 °C ± 2 °C		
Reverse Current	10	mA
Forward Current	10	mA

GB Series: Designed for high-speed applications with reverse bias >5V
GH Series: Designed for applications with reverse bias <5 V
GV Series: Designed for zero bias applications



Package Outlines

TO-39 InGaAs/InGaAs

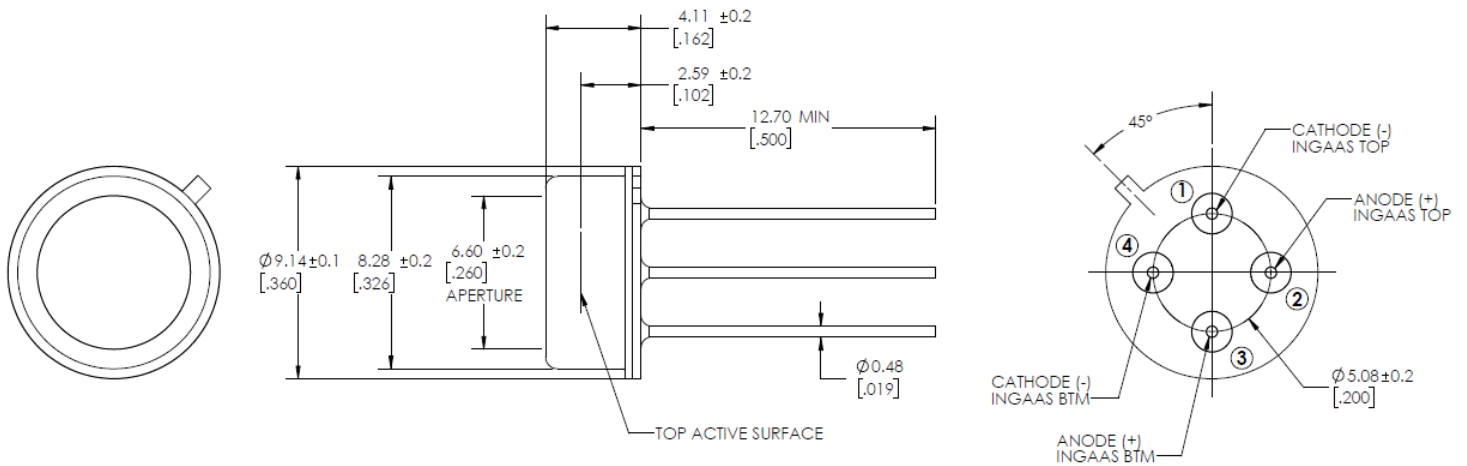

TO-39 Si/InGaAs

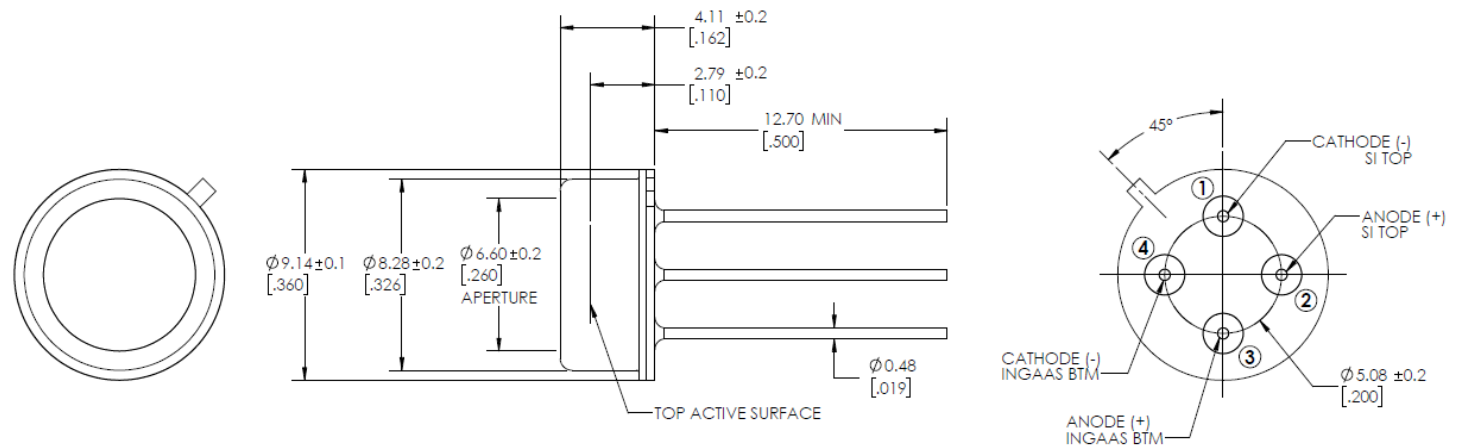

DIMENSIONS IN MM [INCH]

Package Outlines

TO-8 Si/Ge

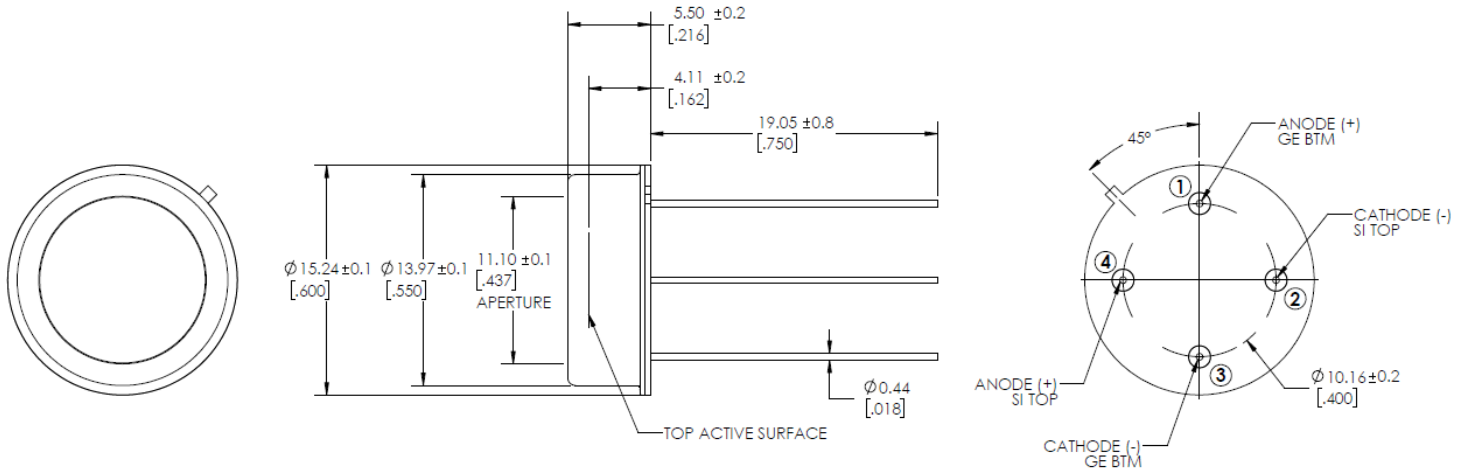

DIMENSIONS IN MM [INCH]



Ordering Information

GPD is proud to offer multiple packaging solutions to best fit the needs of your application. Our Standard configurations are mentioned below, and custom packaging is also available.

Selection is based on the size of the photodiode and the package requirements of your application. Refer to packaging capabilities chart below for more information.

InGaAs over InGaAs

2C-200N17-200N17-T39

Two-Color	InGaAs Top Chip		InGaAs Bottom Chip		Package*	
	200N17	2mm dia. 1.7 μ m InGaAs	200N17	2mm dia. 1.7 μ m InGaAs	T39	TO-39
	200N19	2mm dia. 1.9 μ m InGaAs	200N19	2mm dia. 1.9 μ m InGaAs	*More packages available upon request	
	200N21	2mm dia. 2.1 μ m InGaAs	200N21	2mm dia. 2.1 μ m InGaAs		
	200N22	2mm dia. 2.2 μ m InGaAs	200N22	2mm dia. 2.2 μ m InGaAs		
	200N26	2mm dia. 2.6 μ m InGaAs	200N26	2mm dia. 2.6 μ m InGaAs		

NOTE: GPD Optoelectronics may update product details without prior notice, and any use or application of our products is at your own discretion.

Ordering Information

Si over InGaAs

2C-266S-100N17-T39

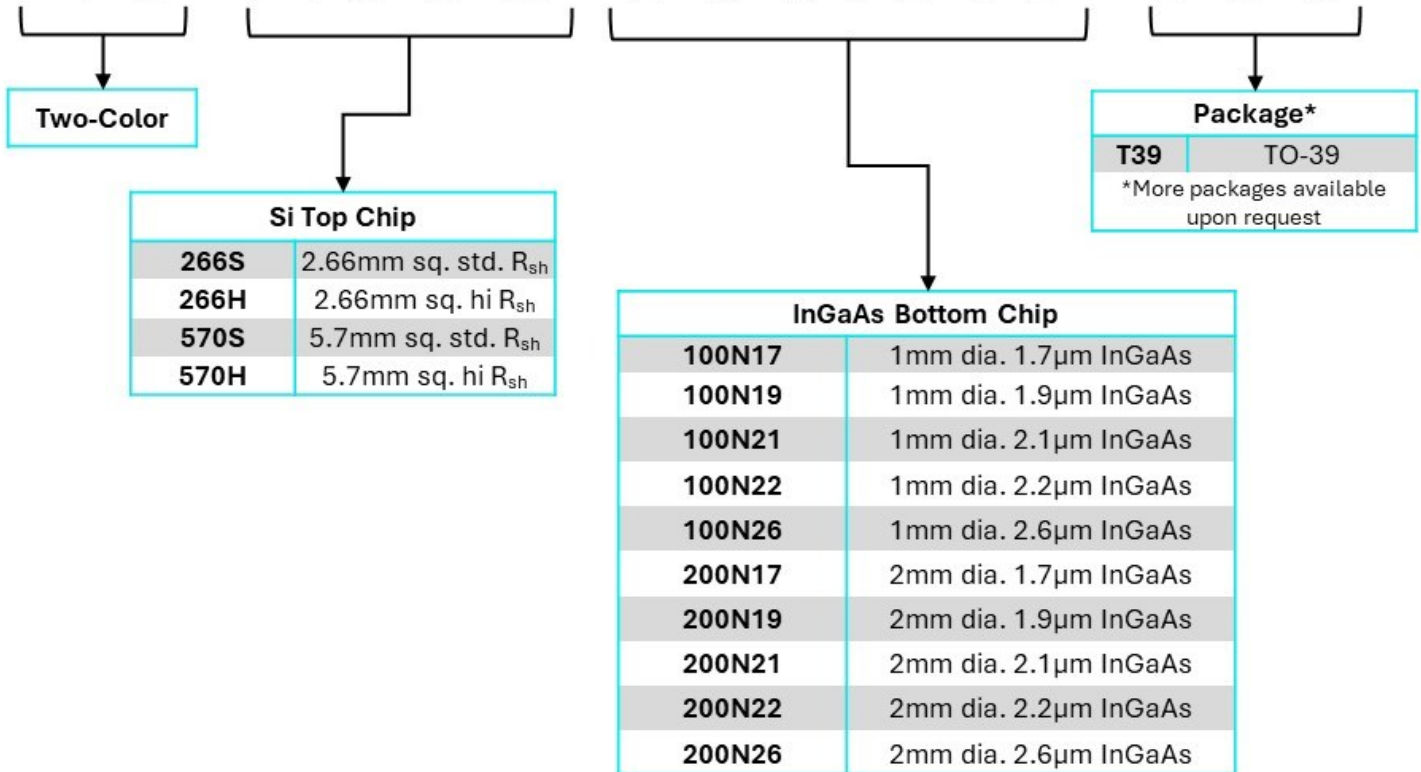

Ordering Information

Si over Ge

2C-570S-500GB-T8

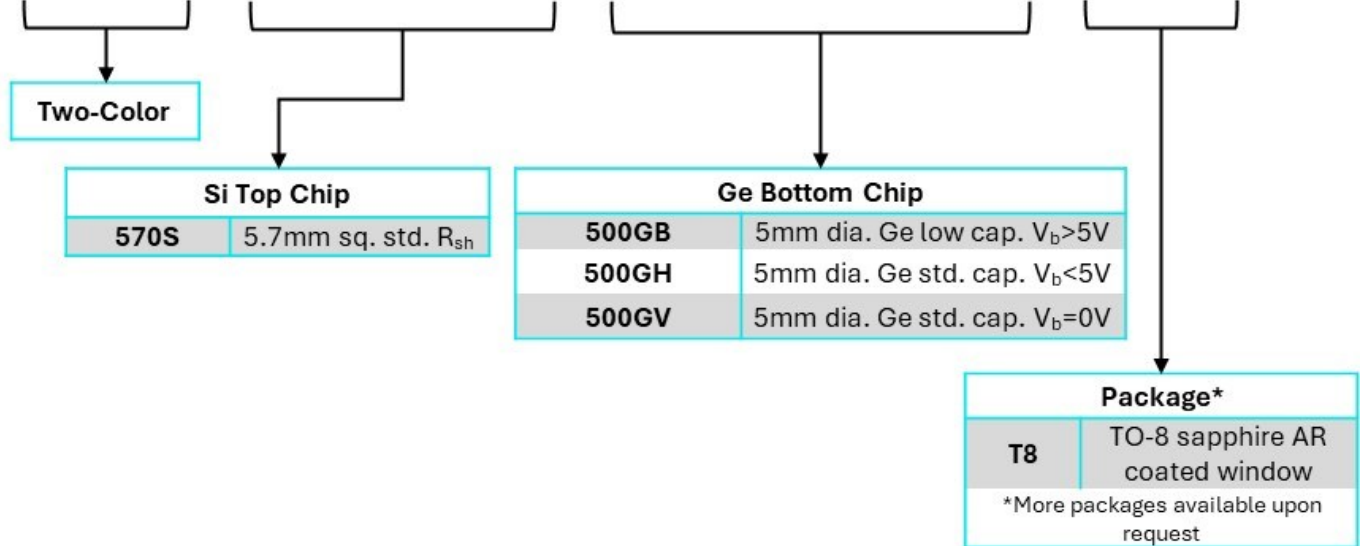

Handling and Processing Precautions

Electrostatic Discharge (ESD) Warning

Our detectors are highly susceptible to damage from electrostatic discharge (ESD). To prevent damage, use ESD protective measures, such as grounding straps, when unpacking and handling these devices.

To guarantee the optimal performance of a photodiode, it is crucial to adhere strictly to the device's electrical specifications. Photodiodes are highly sensitive to values that surpass their absolute maximum ratings. Exceeding these limits can lead to damage or total failure of the device. Users should employ handling techniques that avoid electrostatic discharges and other electrical surges during both the handling and operation of these devices.

Cleanroom Packaging and Handling

Our detectors are packaged in a clean state under cleanroom conditions, eliminating the need for cleaning before processing. In fact, cleaning is not recommended as it may introduce contaminants.

Processing Guidelines

To maintain the cleanliness of our detectors:

- Process under the cleanest conditions possible, including clean workplaces and room air.
- Wear suitable gloves or fingerstalls to prevent fingerprint contamination (mainly fats and organic acids).
- Ensure the soldering process is designed to prevent the need for post-soldering cleaning.
- Solderable pre MIL-STD-750.2026, not to exceed 230°C

Cleaning Optical Windows (if necessary)

If exceptional circumstances require cleaning the optical windows:

- First, identify the type of contamination.
- For loose particles, gently blow them off with nitrogen gas or clean, dry air.
- For attached particles or other contaminating materials, clean with solvents such as isopropyl alcohol, or First Contact™ Polymer